

## TYPE: TELSHACK-B



# TELSHACK-B Wireless Crosby™ Bow Load Shackle

## Description

The TELSHACK-B range of telemetry load shackles are manufactured using the Crosby™ G2130 (12 to 25 tonne) and G2140 (40 to 120 tonne) shackles. Suitable for use in a wide range of industrial and marine weighing applications, these load shackles are robust, reliable and easy to install.

The unique telemetry housing is manufactured from tough high performance polyamide resin making it strong yet light, resulting in a better balanced load shackle when compared to others available on the market. Two clips enable you to open the housing to access and change the two AAA alkaline batteries, while the internal electronics underneath remain completely sealed. This includes the antenna to ensure maximum protection from damage. The built in radio telemetry electronics operates on the 2.4GHz license free frequency.

The TELSHACK-B is also supplied as standard with a handheld battery powered display which can toggle between tonnes or lbs, or alternatively, for multi-shackle applications, a single display can address up to 12 shackles for individual monitoring, or for summation/balancing applications.

LCM Systems can also supply more complex telemetry systems. For further information on what we can offer, please contact our technical department with details of your application requirements.

## Specification

Rated load (tonnes)	12, 17, 25, 40, 55, 85, 120,
Proof load	150% of rated load
Ultimate breaking load	300% of rated load
Non-linearity	<±1% of rated load (typically)
Non-repeatability	<±0.1% of rated load
Transmission distance	Up to 600 metres (clear line of sight)
Battery life	>300 hours typically (continuous use with 1.2Ah batteries)
Battery	2 x AAA Alkaline (supplied with 1.2Ah batteries)
Operating temperature range	-20 to +55°C
Environmental protection level	IP67
Telemetry housing	Polyamide resin

## Available Options

- Special ranges and capacities up to 2000t
- Centralising load bobbin
- Special telemetry systems available
- Lloyds, ABS, DNV or other third party witnessing

## Features

- Ranges from 12 to 120 tonnes
- High tensile carbon steel construction
- Environmentally sealed to IP67
- Simple installation and operation
- Shackle and load pin fully certified
- Optional load centralising bobbin
- Many other options available

## Typical Applications

- Under-hook hoist/crane weighing
- Cable tension monitoring
- Towing/mooring Tension
- Crane safe load monitoring
- Beam proof loading

### LCM Systems Ltd

Unit 15, Newport Business Park  
Barry Way, Newport  
Isle of Wight PO30 5GY UK  
Tel: +44 (0)1983 249264  
Fax: +44 (0)1983 249266  
sales@lcm systems.com  
www.lcm systems.com

# TELSHACK-B Wireless Crosby™ Bow Load Shackle

## Special Options

Special ranges	The TELSACK-B can be supplied in any range, between 12te and 120te and calibrated as required. Usually we will choose the nearest standard shackle size. We can also offer special design shackles up to 2000te. Please contact our sales team for more details.
Centralising bobbin	We can offer an optional centralising bobbin. This helps improve the overall load cell accuracy in certain cable tension applications. The bobbin is shown pictorially in the drawing below.
Multi-shackle systems	It is possible with the standard handheld telemetry display to use up to 12 shackles with a single handheld. Each shackle is paired with the handheld and can be used to view individual load cells or summated load cells. These values can be sent to a printer or a PC.



## Dimensions

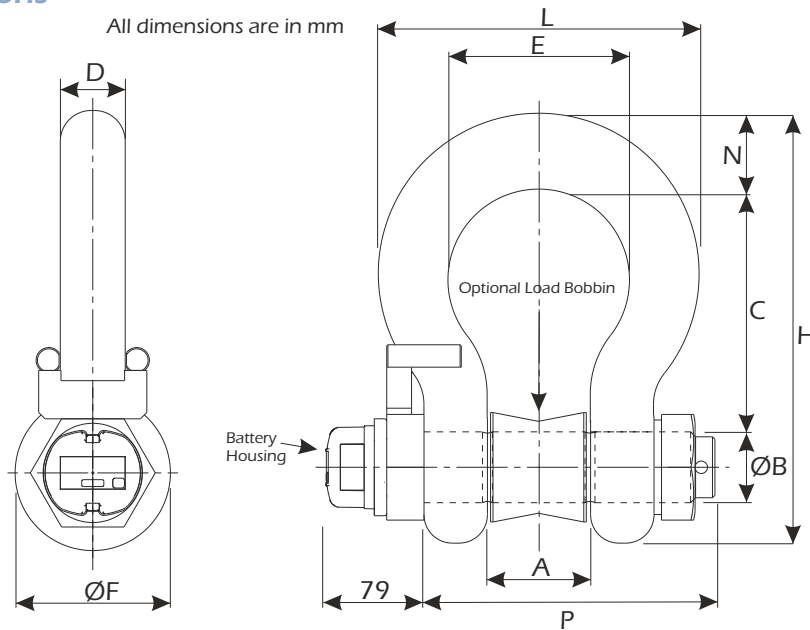

Rating (tonnes)	A	ØB	C	D	E	ØF	H	L	N	P	Weight (kgs)	Resolution (tonnes)
12	51.5	35.1	119	31.8	82.5	76	210	146	35.1	171	8	0.01
17	60.5	41.4	146	38.1	98.5	92	254	175	41.1	201	12	0.02
25	73	51	178	44.5	127	106	313	225	57	236	18	0.02
40	73.2	50.8	178	46.7	127	106	313	224	57.2	236	18	0.05
55	82.6	57.2	197	52.8	146	122	347	258	61	269	25	0.05
85	105	69.9	267	68.8	184	148	455	324	79.2	351	45	0.1
120	127	82.6	330	79.2	200	165	546	371	92.2	387	85	0.1

www.lcm systems.com



**SCIGATE AUTOMATION (S) PTE LTD**

No. 1 Bukit Batok Street 22 #01-01 Singapore 659592  
**Tel: (65) 6561 0488** **Fax: (65) 6562 0588**  
 Email: sales@scigate.com.sg Web: www.scigate.com.sg

Business Hours: Monday - Friday 8.30am - 6.15pm

Due to continual product development, LCM Systems Ltd reserves the right to alter product specifications without prior notice.

Issue No. 3

Issue date: 08/02/2017

APPROVED

(unapproved if printed)